

# Midland Handling Equipment Ltd

STRETTON ROAD, GREAT GLEN, LEICESTER. LE8 9GN

Telephone 0116-2593175 Fax 0116-2592820

E-mail [enquiries@mhel.co.uk](mailto:enquiries@mhel.co.uk)



## Trakmaster 406 Heavy duty

## Data Sheet

### Chain

Fully bi-planer and assembled in our works from hardened steel side links, cast iron cruciform, and hardened twin ball bearing wheels fitted to both the vertical and horizontal side links with pendants at multiples of 406mm pitch. Safe load per pendant **100kg, 150kg** per coupled pendant. Maximum chain breaking stain is 10,000 lbs.

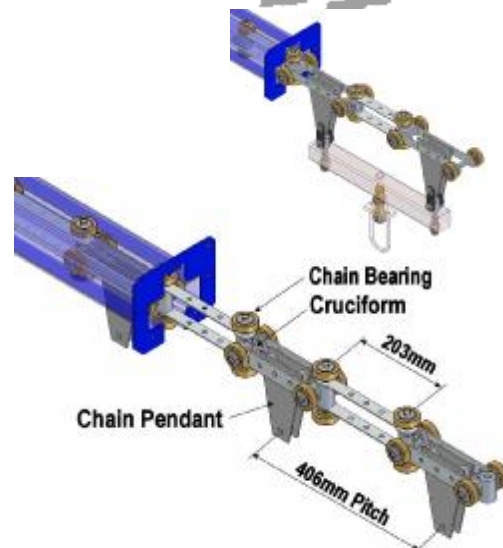

### Track

The track is rolled from mild steel in 3 metre long sections maximum. Two 'top hat' track sections are welded facing each other spaced with bridge plates at 750 pitch. Vertical and horizontal track curves are rolled from the same track section.

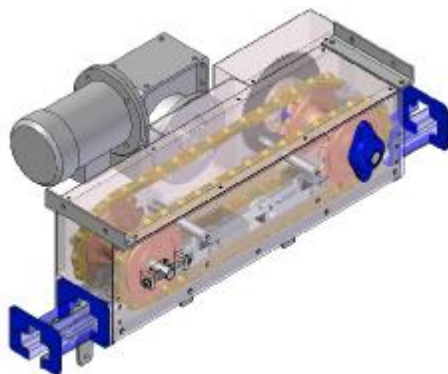

### Drive

The caterpillar drive unit has engaging dogs to provide a smooth transition to the main chain. The unit would be driven by an in-line geared motor and incorporating a torque limiting device for overload protection. An inverter variable speed (5:1 ratio) or thyristor (10:1 ratio) is available.

### Tension Unit

A spring loaded tension device would be fitted to ensure correct chain tension and to compensate for variances within the system.

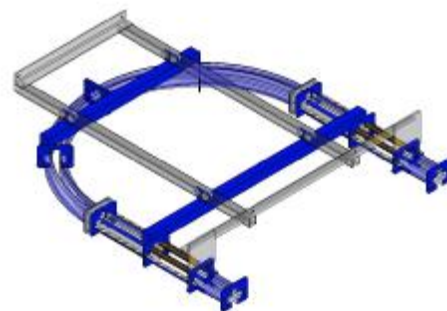

### Inspection

This would be incorporated in a readily accessible position in the circuit for inspection and preventative maintenance.



### Support Structure

The conveyor would be either floor supported using square hollow section forming a rigid structure and incorporating base plates, or roof supported utilising track hanger clamps connected to tubular suspensions. Please see specification for specific proposals.

### Carriers

Please see specification for details. The conveyor incorporates pendants at multiples of 152mm pitch.

### Finish

Track & steelwork finished in mid blue paint, machined parts self colour.