

Midland Handling Equipment Ltd

STRETTON ROAD, GREAT GLEN, LEICESTER. LE8 9GN

Telephone 0116-2593175 Fax 0116-2592820

E-mail enquiries@mhel.co.uk



Trakmaster 228 Medium duty

Data Sheet

Chain

Fully bi-planer and assembled in our works from hardened steel side links, sintered metal pivot blocks, and hardened twin ball bearing wheels fitted to both the vertical and horizontal side links with pendants at multiples of 228mm pitch. Safe load per pendant **30kg, 60kg** per coupled pendant. Maximum chain breaking stain is 3,000 lbs.

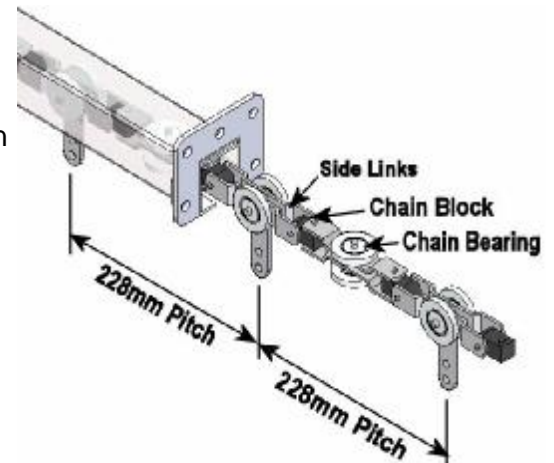

Track

From high quality steel rolled to form a 51mm square section with 3mm wall thickness complete with a 9mm slot. Horizontal and vertical curves have the slot machined after manufacture and finally hardened.

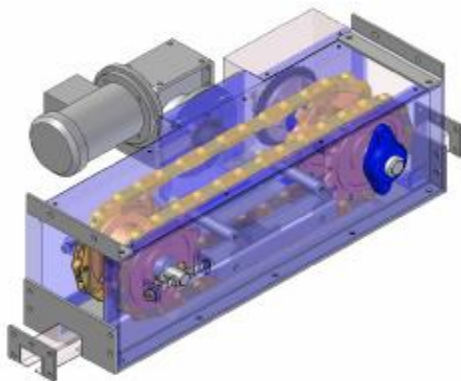

Drive

The caterpillar drive unit has engaging dogs to provide a smooth transition to the main chain. The unit would be driven by an in-line geared motor and incorporating a torque limiting device for overload protection. An inverter variable speed (5:1 ratio) or thyristor (10:1 ratio) is available.

Tension Unit

A spring loaded tension device would be fitted to ensure correct chain tension and to compensate for variances within the system.

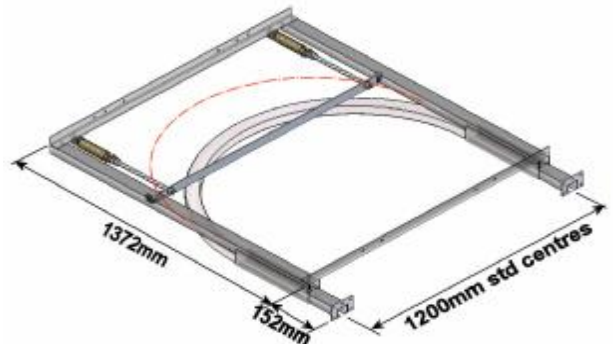

Inspection

This would be incorporated in a readily accessible position in the circuit for inspection and preventative maintenance.

Support Structure

The conveyor would be either floor supported using square hollow section forming a rigid structure and incorporating baseplates, or roof supported utilising track hanger clamps connected to tubular suspensions. Please see specification for specific proposals.

Carriers

Please see specification for details. The conveyor incorporates pendants at multiples of 228mm pitch.

Finish

Track galvanised, steelwork finished mid blue paint, machined parts self colour.